

# FURUNO

# OPERATOR'S MANUAL

**LOUD HAILER**

---

**MODEL LH-3000**

---



**FURUNO ELECTRIC CO., LTD.**  
NISHINOMIYA, JAPAN

© **FURUNO ELECTRIC CO., LTD.**

9-52 Ashihara-cho,  
Nishinomiya 662-8580, JAPAN

Telephone : 0798-65-2111

Fax : 0798-65-4200

All rights reserved.

Printed in Japan

Pub. No. OME-56460

( DAMI ) LH-3000

Your Local Agent/Dealer

FIRST EDITION : FEB. 2004

A4 : AUG. 24, 2004



\* 0 0 0 1 4 9 1 1 8 0 0 \*



\* O M E 5 6 4 6 0 A 4 0 \*



# SAFETY INSTRUCTIONS

## **WARNING**

### **Do not open the equipment.**

Only qualified personnel should work inside the equipment.

### **Do not disassemble or modify the equipment.**

Fire, electrical shock or serious injury can result.

### **Do not place liquid-filled containers on the top of the equipment.**

Fire or electrical shock can result if a liquid spills into the equipment.

### **Immediately turn off the power at the switchboard if the equipment is emitting smoke or fire.**

Continued use of the equipment can cause fatal damage to the equipment. Contact a FURUNO agent for service.

### **Make sure no rain or water splash leaks into the equipment.**

Fire or electrical shock can result if water leaks in the equipment.

### **Keep heater away from equipment.**

A heater can melt the equipment's power cord, which can cause fire or electrical shock.

### **Use the proper fuse.**

Use of a wrong fuse can result in damage to the equipment.

## **CAUTION**

### **Do not use the equipment for other than its intended purpose.**

Use of the equipment for other than its intended purpose may result in damage to the equipment or cause bodily injury.

### **Observe the following compass safe distances to prevent interference to a magnetic compass:**

	Standard compass	Steering compass
LH-3000	1.55 m	1.00 m
LH-3010	2.15 m	1.40 m

# TABLE OF CONTENTS

---

<b>FOREWORD .....</b>	<b>iii</b>
<b>SYSTEM CONFIGURATION.....</b>	<b>iv</b>
<b>EQUIPMENT LIST.....</b>	<b>iv</b>
<b>1. INSTALLATION .....</b>	<b>1</b>
1.1 Mounting the Loud Hailer .....	1
1.2 Intercom Speaker (option) .....	3
1.3 Wiring.....	4
<b>2. OPERATIONAL OVERVIEW .....</b>	<b>9</b>
2.1 Controls.....	9
2.2 Turning the Power On/Off.....	10
2.3 Adjusting Key Backlighting .....	11
2.4 Adjusting Output Level .....	11
2.5 Adjusting Listening Volume .....	11
2.6 Calling All Intercom Stations .....	11
2.7 Calling a Specific Intercom Station .....	12
2.8 Receiving a Call from an Intercom Station.....	12
2.9 Hailing by Voice.....	13
2.10 Sounding Warning Signals .....	14
2.11 Transmitting the Auxiliary Signal.....	18
2.12 Alarm Mode.....	19
<b>3. MAINTENANCE, TROUBLESHOOTING .....</b>	<b>21</b>
3.1 Preventive Maintenance.....	21
3.2 Replacing the Fuse .....	22
3.3 Troubleshooting.....	22
<b>SPECIFICATIONS.....</b>	<b>SP-1</b>
<b>PACKING LIST</b>	
<b>OUTLINE DRAWINGS</b>	
<b>INTERCONNECTION DIAGRAM</b>	

# FOREWORD

---

## A Word to the Owner of the LH-3000

Congratulations on your choice of the FURUNO LH-3000 Loud Hailer. We are confident you will see why FURUNO has become synonymous with quality and reliability.

For over 50 years FURUNO Electric Company has enjoyed an enviable reputation for innovative and dependable marine electronics equipment. This dedication to excellence is furthered by our extensive global network of agents and dealers.

Your Loud Hailer is designed and constructed to meet the rigorous demands of the marine environment. However, no machine can perform its intended function unless installed, operated and maintained properly. Please carefully read and follow the recommended procedures for installation, operation and maintenance.

We would appreciate hearing from you, the end-user, about whether we are achieving our purposes.

Thank you for considering and purchasing FURUNO equipment.

## Features

- 30 W audio output power to get another boat's attention under almost any condition.
- Eight internationally accepted warning signals can be selected for automatic operation for a variety of different maritime situations alerting nearby vessels of your presence and status in low visibility conditions.
- Four intercom stations (speakers) may be connected to get 2-way communications between master station and one or all intercom stations.
- LED indicators alert you to equipment status.
- Keys are backlit for nighttime operation.
- Smartly designed and intuitive front panel for ease of operation.
- An auxiliary audio input allows transmission of music or other external audio signals (from cassette player, CD player, radio, etc.) to the intercom speakers, external horns or both.

# SYSTEM CONFIGURATION

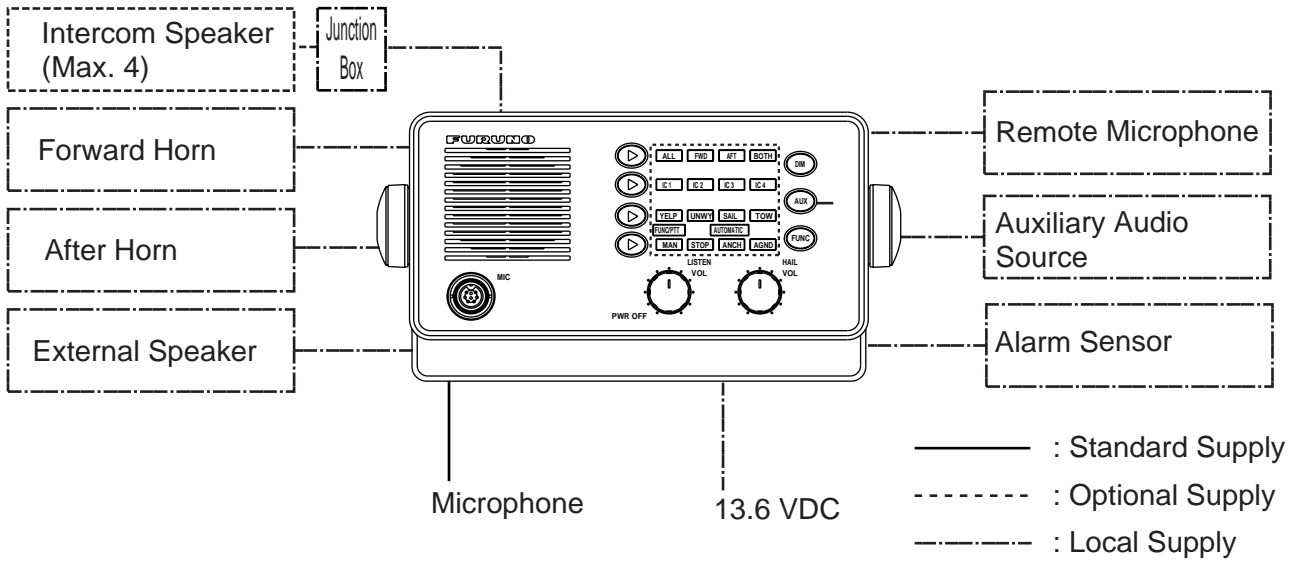

System configuration

# EQUIPMENT LIST

## Standard supply

Name	Type	Code No.	Qty	Remarks
Loud Hailer	LH-3000		1	See packing list for details.
Microphone Set	DM-2003		1 set	
Installation Materials			1 set	
Spare Parts			1 set	
Template	E52-00303	000-149-157	1	

## Optional supply

Name	Type	Code No.	Qty	Remarks
Intercom Speaker	LH-3010	000-149-111	1	Max. 4
Flush Mount Kit	LH-3020	000-149-112	1	See packing list.
Twisted Pair Cable	CO-SPEVV-SB-C 0.2X2P	000-111-680	1	5 m
		000-120-792	1	10 m
		000-120-793	1	15 m
		000-120-794	1	20 m

# 1. INSTALLATION

---

## 1.1 Mounting the Loud Hailer

The Loud Hailer can be mounted on a desktop, on the overhead, on a bulkhead or flush mounted in a panel (optional kit required). Refer to the mounting template (supplied) for installation instructions.

### Mounting considerations

When planning the location for the Loud Hailer, keep in the mind the following considerations.

- Locate the unit where the front panel can be easily viewed and operated.
- Leave sufficient space at the sides and rear of your unit for ease of maintenance.
- Locate the unit as near to the power source as possible.
- The location should be out of direct sunlight because of heat that can build up inside the cabinet.
- Choose a location not subject to rain and salt spray.
- Locate the unit well away from sources of noise such as motors, alternators and generators.

### Mounting procedure

#### Desktop, bulkhead, overhead mounting

1. Attach rubber cushions (supplied) to the body of the Loud Hailer. Position the cushions so they locate across from the bottom of the slot in the hanger regardless of mounting method.

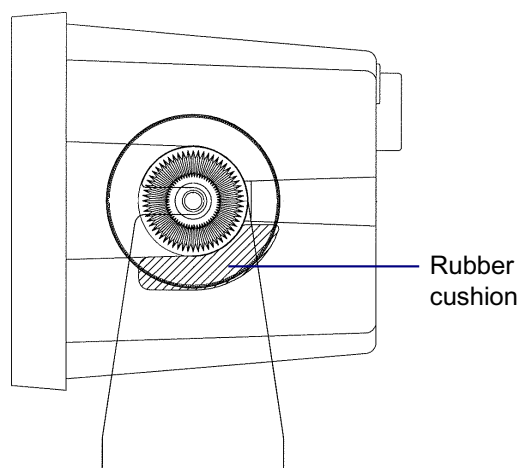

2. Fix the hanger to the mounting location with tapping screws (6x20).
3. Screw knob bolts into the Loud Hailer.
4. Set the Loud Hailer to the hanger and tighten knob bolts.

## 1. INSTALLATION

### **Flush mounting**

Requires flush mount kit LH-3020 (Code No. 000-149-112). See the flush mount outline drawing for details.

#### *Contents of flush mount kit*

<b>Name</b>	<b>Type</b>	<b>Code No.</b>	<b>Qty</b>
Flush Mounting Plate	TZ7300012A	999-999-025	2
Screw	6X12 SUS304	999-999-027	2
Wing Screw	M4X35 SUS304	999-999-027	4
Wing Nut	M4 SUS304	999-999-028	4

1. Make a cutout in the mounting location referring to flush mount outline drawing.
2. Place the Loud Hailer in the cutout.
3. Fix the two flush mounting plates to the Loud Hailer with screws.
4. Screw the wing nuts on the wing screws.
5. Fix the Loud Hailer with the wing bolts and then tighten the wing nuts.

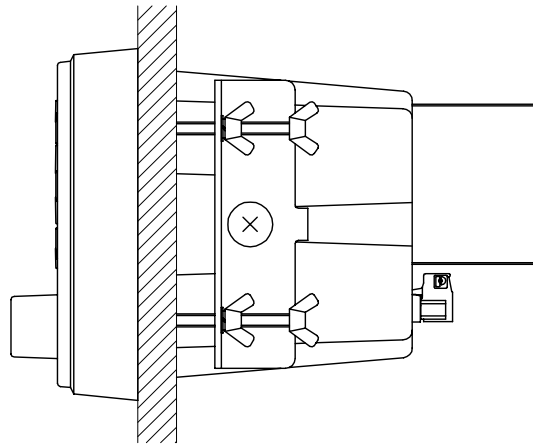

*Loud hailer, flush mount*

## 1.2 Intercom Speaker (option)

Four intercom speakers (maximum) may be connected to get 2-way communications between master station and one or all intercom speakers. For mounting dimensions and fixing instructions, see the outline drawing.

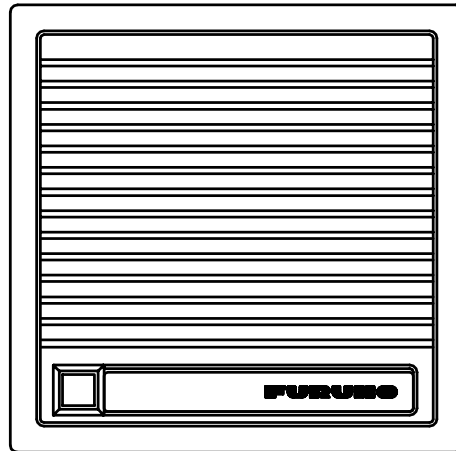

*Intercom speaker*

## 1.3 Wiring

All equipment are terminated at the rear panel of the LH-3000. See the illustration on the next page for how to connect equipment to terminals. Refer to the interconnection diagram for detailed information.

### Rear panel layout

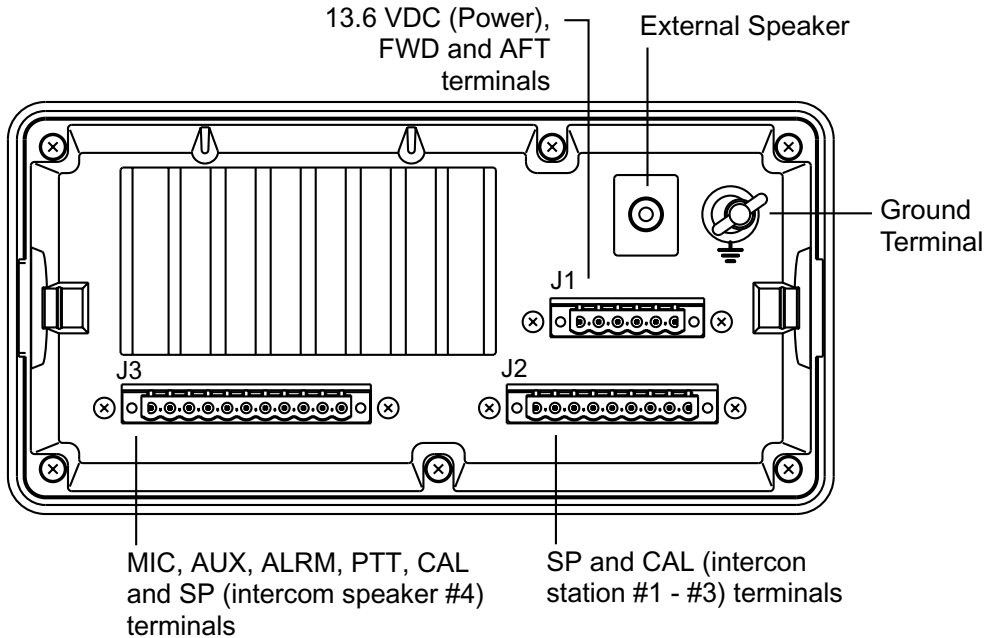

#### NOTICE

Connect drain wires of armored cables to the ground terminal. Do not short them to the heat sink.

*LH-3000, rear panel*

## Wiring

The illustration below shows how to connect the power supply. Other equipment are connected similarly.

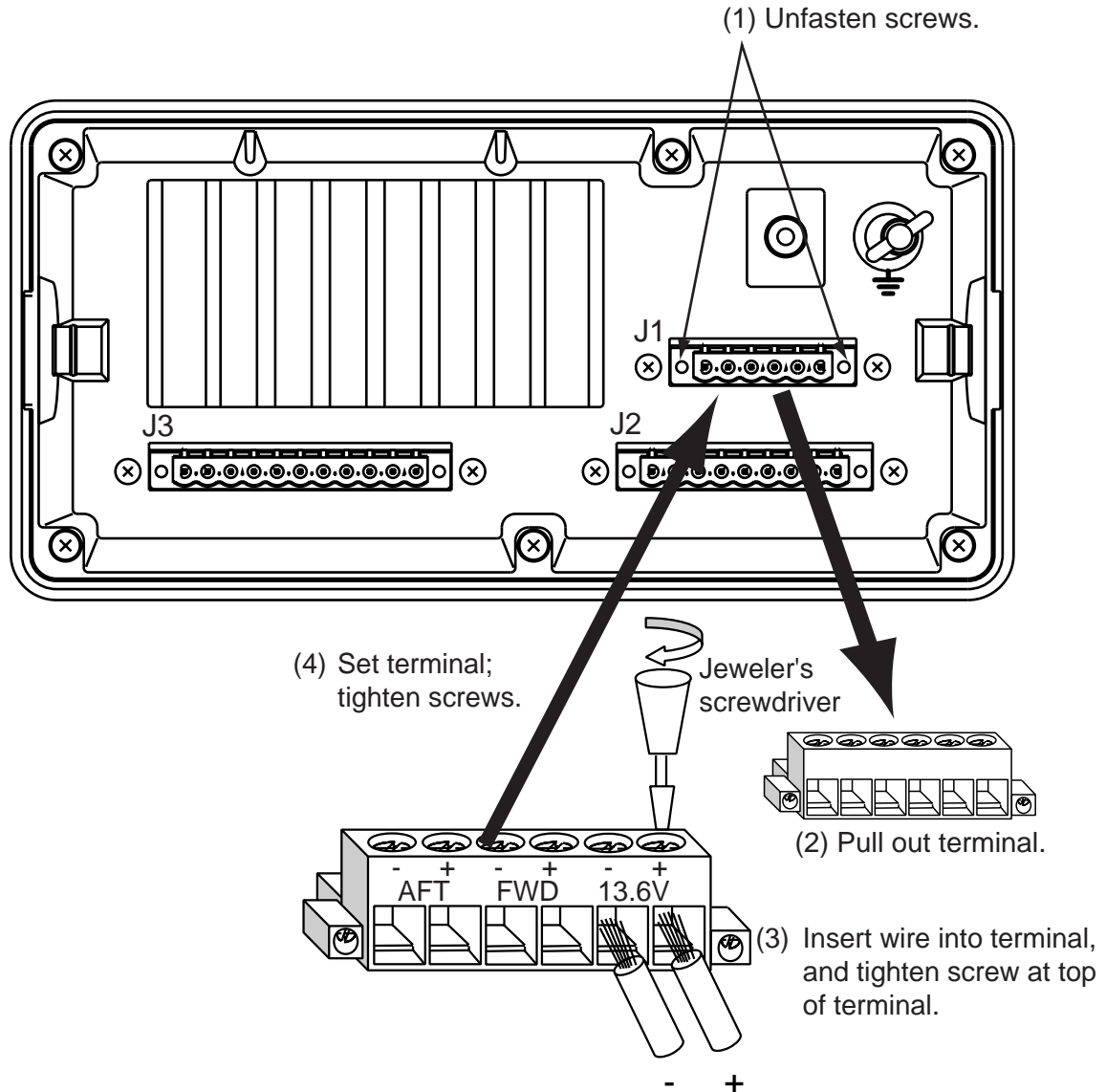

### TERMINAL ARRANGEMENT

J1

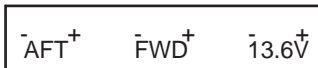

J2



J3



**Note 1 :** Connect power cables to the battery correctly.

**Note 2:** Connection of intercom speaker cable to J2 or J3:

Brown: CAL

Red: SP1

Black: 0V1

LH-3000, rear panel, how to wire terminals

# 1. INSTALLATION

## **Power connection**

The LH-3000 is intended for use with a 13.6 VDC power supply. Connect the power cable ( local supply) to the terminals labeled "13.6V". Use cable type DPYC-1.5 or equivalent. Fabricate the cable as shown below. For longer runs the wire size of leads should be increased accordingly to minimize line

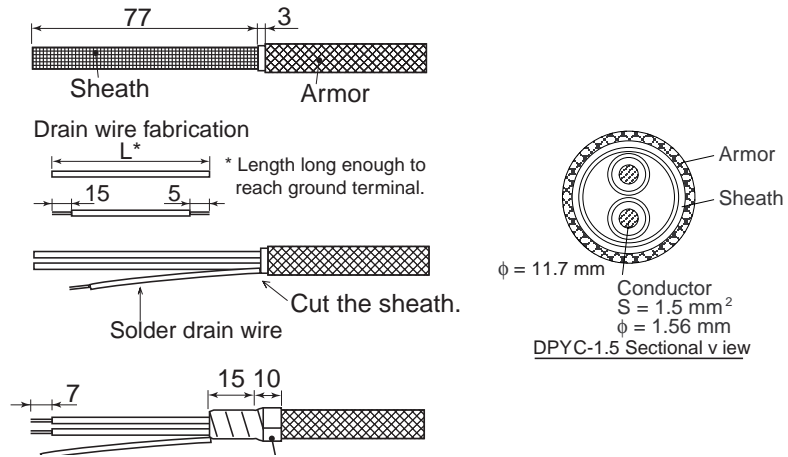

losses. The wire connected to the positive (+) terminal must be connected to the positive terminal on the DC power source, and the wire connected to the negative terminal (-) must be connected to the negative terminal on the DC power source. If the power leads are reversed the fuse ( inside the Loud Hailer) will blow.

## **Intercom speaker (option)**

Up to four intercom speakers may be connected to the intercom speaker terminals labeled CAL1-CAL4. Connect each speaker to the terminal block according to desired intercom speaker selection. The cable end is prefabricated. However, to meet EMC requirements the length of the cable must be less than 1 m. If the distance between the Loud Hailer and intercom speaker is greater than 2 m ( max. 20 m) , use a junction box ( local supply) . For the connection to the junction box use cable type CO-SPEVV-SB-C 0.2X2P ( option) and fabricate it as below. In this case, the length of the cable between the junction box and an intercom speaker must not be more than 1 m regardless of whether the equipment must meet EMC requirements or not.

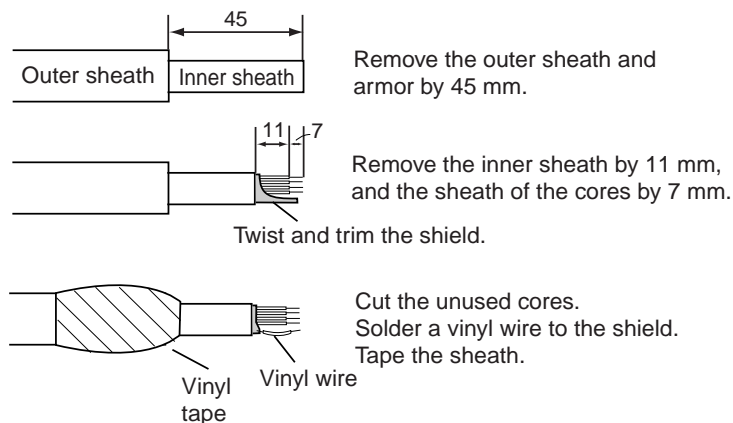
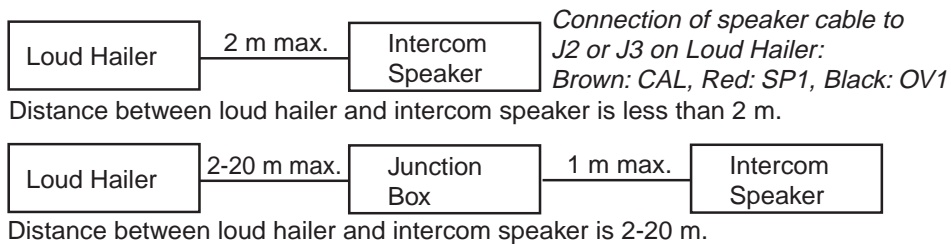

*Fabrication of speaker cable*

**Hailer horn (local supply)**

Mount the hailer horns (local supply) facing away from the Loud Hailer to prevent feedback. They should also be pointed in the opposite direction of the microphone as you are speaking into it. Before mounting any horn, you should test it with the HAIL feature with the horn in the desired location to check for suitability of mounting location.

Connect horns to the Loud Hailer with cable type DPYC-1.5 or equivalent. (See page 6 for how to fabricate this cable.) Be sure the cable is suitable for all-weather use. The terminating point on the terminal is either FWD or AFT depending on the location of the speaker.

**Burglar alarm (local supply)**

The unit can function as a burglar alarm by connecting an external alarm sensor (local supply) to the ALRM terminals. The alarm sensor should be a “normally open switch”. Use cable type TTYCS-1 or equivalent to connect the sensor. Fabricate the cable as shown below.

When the sensor connected to the ALRM terminal becomes shorted and the alarm function is active, the yelp signal is released at maximum volume through both hailer horns.

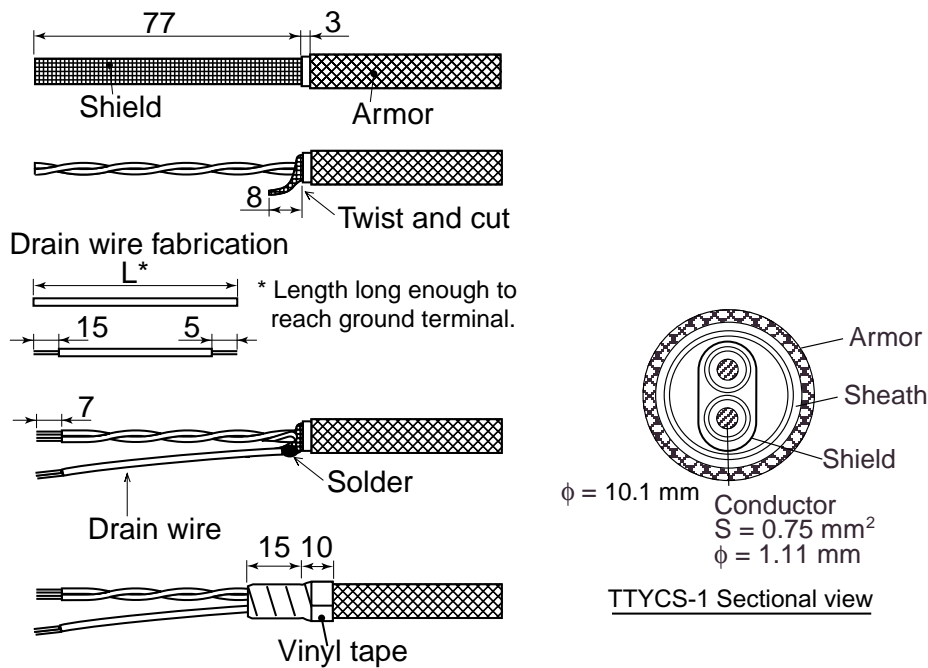

*Fabrication of cable TTYCS-1*

## 1. INSTALLATION

### Floating ground

The LH-3000 has a floating ground. What this means is that the heat sink ground is floating and will not ground batteries if they are connected to the ship's chassis. To maintain a floating ground:

1. Use a stereo plug when connecting a 4 ohm speaker to the external speaker plug. Connect it as shown in the illustration below.

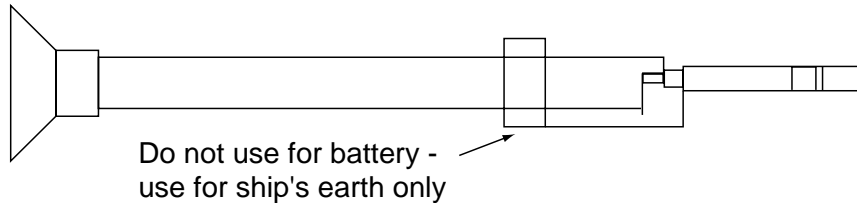

*Stereo plug*

2. Do not connect any of the output connectors on the rear panel to the ship's ground.
3. SP outputs are floating and must not be connected to either battery or the rear panel. Use a normal two conductor insulated speaker wire for the horn speaker.

### Output power

The output power may be set for 30 W or 20 W, and the default settings is 30 W. For 20 W output contact a FURUNO agent or dealer for details.

**Note:** If an external speaker is used it must be capable of handling the rated output power.

# 2. OPERATIONAL OVERVIEW

## 2.1 Controls

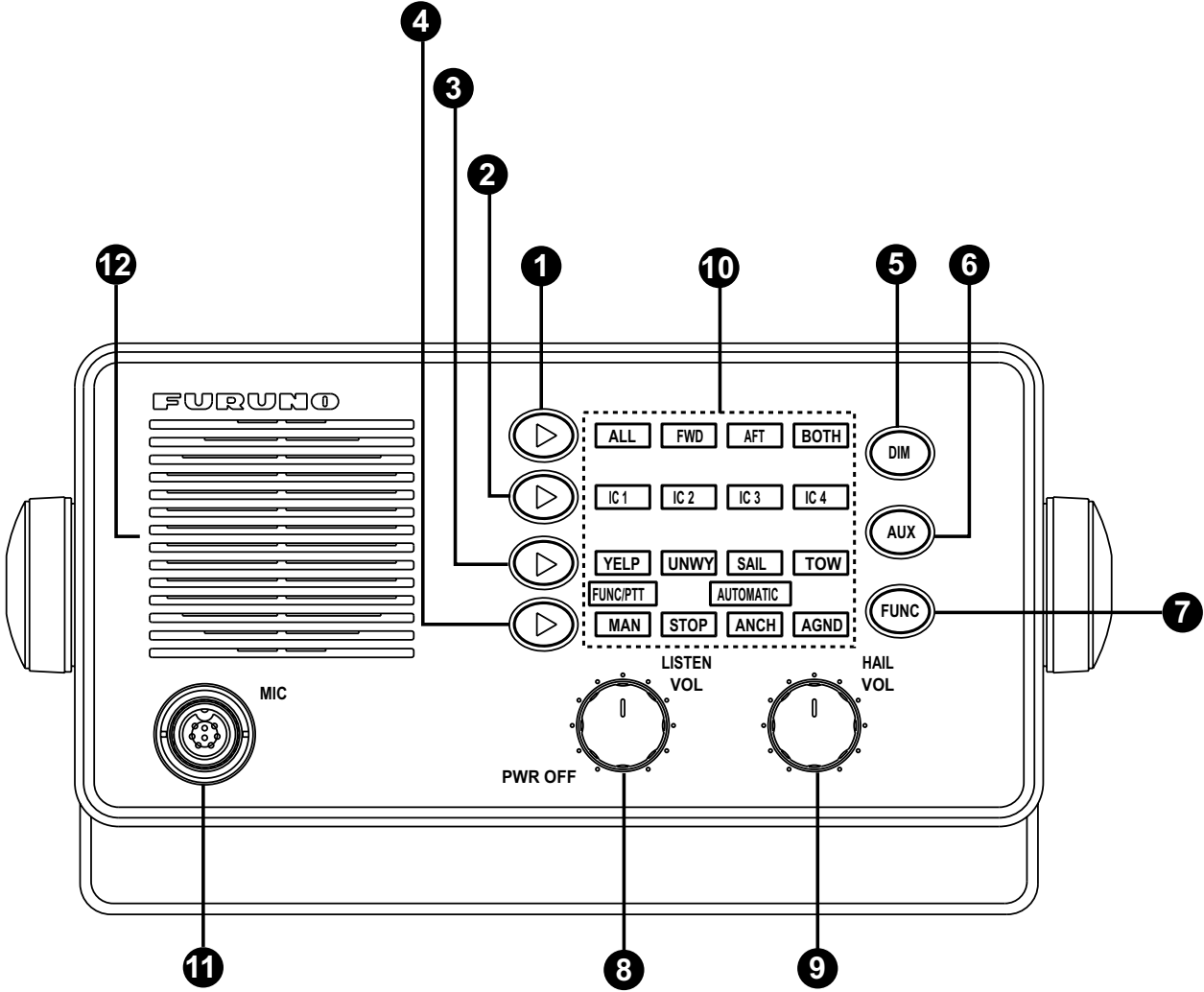

LH-3000, front view

**Control description**

- 1 [Hail Select] Key**      Chooses loud hailer speaker to use (ALL, FWD, AFT, BOTH).
- 2 [Intercom Select] Key**      Chooses which intercom station (IC1, IC2, IC3, IC4) to call.
- 3 [Upper Signal Select] Key**      Chooses warning signal among YELP, UNWY, SAIL and TOW.
- 4 [Lower Signal Select] Key**      Chooses warning signal among MAN, STOP, ANCH and AGND.
- 5 [DIM] Key**      Adjusts indicator backlighting, in five levels, including off.
- 6 [AUX] Key**      Transmits audio signal from external source to all intercom stations.

## 2. OPERATION

- |                        |  |
|------------------------|--|
| ⑦ [FUNC] Key           | Activates automatic and manual warning signals.  |
| ⑧ [LISTEN VOL] Control | Adjusts listening volume from the internal speaker; turns power on/off.  |
| ⑨ [HAIL VOL] Control   | Adjusts output volume from the horn speakers or intercom station speakers.   |
| ⑩ LED Indicators       | From top row: <ul style="list-style-type: none"><li>- Hail indicators (ALL, FWD, AFT BOTH)</li><li>- Intercom indicators (IC1 – IC4)</li><li>- Alarm signal indicators (YELP(manual), UNWY, SAIL, TOW)</li><li>- FUNC/PTT and AUTOMATIC indicators</li><li>- Alarm signal indicators (MAN(manual), STOP, ANCH, AGND)</li></ul> |
| ⑪ MIC                  | MIC input  |
| ⑫ Speaker              |  |

## 2.2 Turning the Power On/Off

Turn the [LISTEN VOL] control clockwise to turn on the Loud Hailer. The “ALL” indicator lights, which means the Loud Hailer is in standby and awaiting your command.

The equipment is in the standby mode when the “ALL” indicator is lit. Normally, the equipment should be returned to the standby mode after a function has been completed. In the standby mode the Loud Hailer is ready to call all stations, including both horn speakers and all intercom stations, and is ready to receive a call from any intercom station.

## 2.3 Adjusting Key Backlighting

You may adjust the intensity of the key backlighting cyclically with the [DIM] key, in five levels, including off.

## 2.4 Adjusting Output Level

Turn the [HAIL VOL] control to adjust the output volume from the horn speakers or intercom speakers. Clockwise rotation increases volume; counterclockwise rotation decreases it.

## 2.5 Adjusting Listening Volume

Turn the [LISTEN VOL] control to adjust the listening volume from the Loud Hailer's internal speaker and external speaker (if connected).

## 2.6 Calling All Intercom Stations

1. In the standby mode, hold the microphone 2-3 cm from your mouth and press the PTT switch on the microphone. Speak into the microphone. All intercom stations and both horn speakers will hear you.
2. After speaking, release the PTT switch to return the equipment to the standby mode.

**Note:** To call all intercom stations while sounding warning signals, see page 17.

## 2.7 Calling a Specific Intercom Station

1. Press the [Intercom Select] key until the indicator lights on the desired intercom station. After a one-second delay, a short tone sounds from the selected intercom station.
2. Press the PTT switch on the microphone and speak into the microphone.
3. Release the PTT switch to listen for a reply from the selected intercom station. If necessary, adjust listening volume with the [LISTEN VOL] control.
4. After completing your conversation, press the [Hail Select] key to return to the standby mode.

**Note:** To call a specific intercom stations while sounding warning signals, see page 17.

## 2.8 Receiving a Call from an Intercom Station

When an intercom station is calling the main station, the indicator for the calling station flashes on the main station's indicator and a tone sounds while the intercom station operator is pressing the station's calling switch.

### Automatically selecting a single calling station

1. In the standby mode, press the PTT switch on the microphone to answer the call. The LH-3000 automatically switches to the calling station and the flashing indicator then lights steadily.
2. If necessary, adjust listening volume with [LISTEN VOL] control.
3. After you have finished your conversation, press the [Hail Select] key to return to the standby mode.

### Automatically selecting multiple calling stations

When you receive a call from more than one station, the appropriate intercom station indicators flash and a tone sounds.

1. In the standby mode, press the PTT switch on the microphone. When calls are received simultaneously, the low-number station will be selected first.
2. After you have completed your conversation, press the [Hail Select] key to return to the standby mode.
3. Press the PTT switch on the microphone again and the next low-number station will automatically be selected.
4. After you have finished all intercom conversations, press the [Hail Select] key to return to the standby mode ("ALL" indicator lights).

### Calling all intercom stations while an intercom voice is selected

1. Press and hold the [Hail Select] key.
2. Press the PTT switch on the microphone and speak into the microphone. All station indicators flash.

### **Manually selecting a calling station**

1. Press the [Intercom Select] key until the indicator lights for the desired station.
2. Press the PTT switch on the microphone and answer the call.
3. Release the PTT switch to listen to the intercom station. Adjust listening volume with the [LISTEN VOL] control if necessary.
4. To call another station, select the next station with the [Intercom Select] key.
5. After you have finished all conversations, press the [Hail Select] key to return to the standby mode.

### **Intercom station operation**

Press the button on the intercom to call. Release the button to listen.

## **2.9 Hailing by Voice**

1. Press the [Hail Select] key until the indicator lights for the desired horn speaker(s).
2. Press the PTT switch on the microphone and speak into the microphone. If necessary, adjust the output power to the speaker(s) with the [HAIL VOL] control.
3. Release the PTT switch and the Loud Hailer will switch to the listening mode, using the speaker(s) as microphone(s). If necessary, adjust listening volume with the [LISTEN VOL] control.
4. After speaking, press the [Hail Select] key to return to the standby mode.

## 2.10 Sounding Warning Signals

Your Loud Hailer has eight different warning signals: two manual and six automatic. The two manual signals, YELP and MAN, are designed to be sounded at each press of the PTT switch on the microphone. The six automatic signals are sounded when the [FUNC] key is operated.

Only the horn speakers sound warning signals and the volume is automatically set to maximum when sounding warning signals.

### Description of warning signals

#### Manual warning signals

MAN: Signal for passing. The lengths and timing of the horn blasts are controlled by pressing the PTT switch on the microphone.

YELP: Yelp type emergency siren.

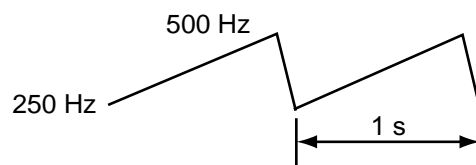

*Yelp signal*

#### Automatic warning signals

UNWY: Warning signal for power-driven vessels underway. One 5-second blast at 120 second interval intervals.

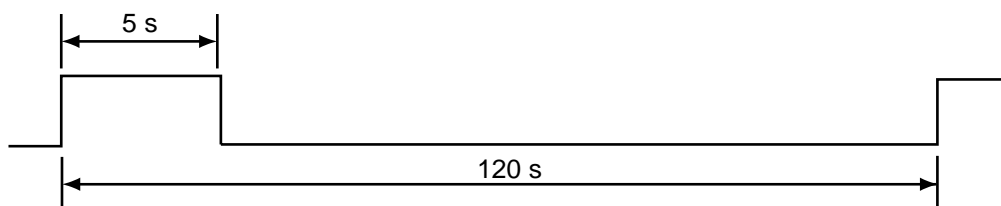

*Underway signal*

**SAIL:** Warning signal for sailboats, tug boats and tow boats underway. One 3-second blast, followed by one 2-second interval, one 1-second blast, one 2-second interval and one 1-second blast. Repeated every 120 seconds.

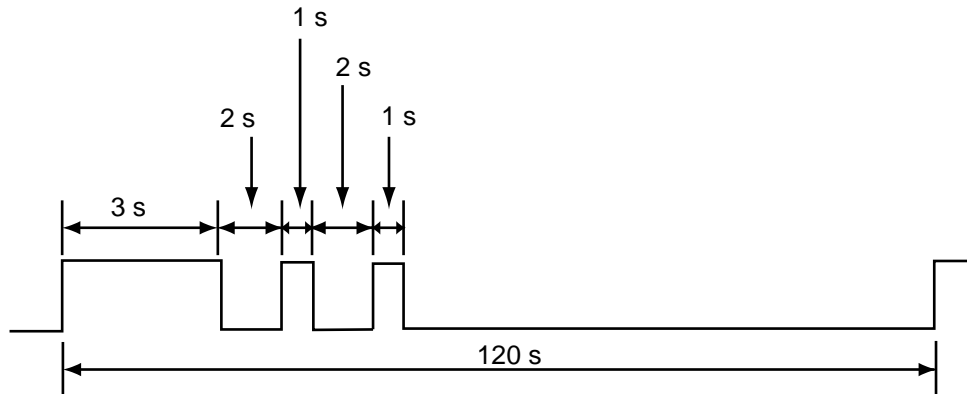

*Sailing signal*

**TOW:** Warning signal for vessels under tow. One 3-second blast, followed by one 2-second interval, one 1-second blast, one 2-second interval, one 1-second blast, one 2-second interval, and one 1-second blast. Repeated every 120 seconds.

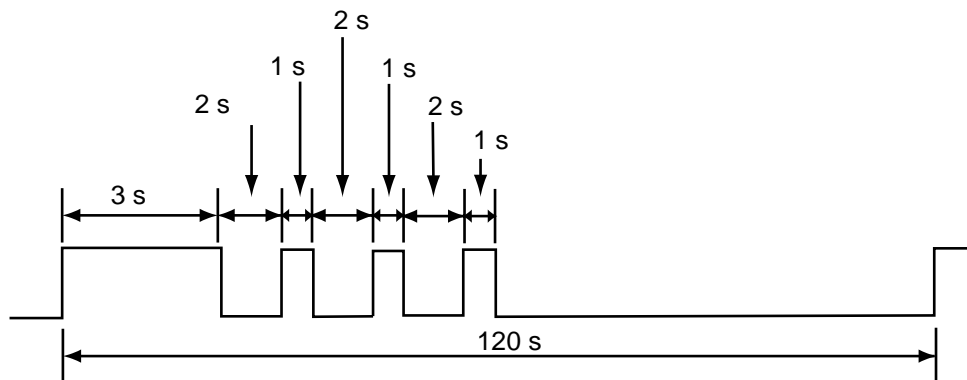

*Towing signal*

**STOP:** Warning signal for power-driven vessel that is stationary. Two 3-second blasts, with a 2-second interval between each blast, repeated every 120 seconds.

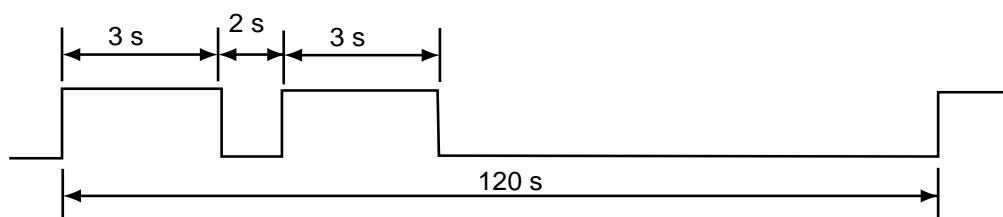

*Stop signal*

## 2. OPERATION

ANCH: Warning signal for vessels at anchor. A rapidly ringing bell tone sounds for a duration of 5 seconds, repeated at an interval of 60 seconds.

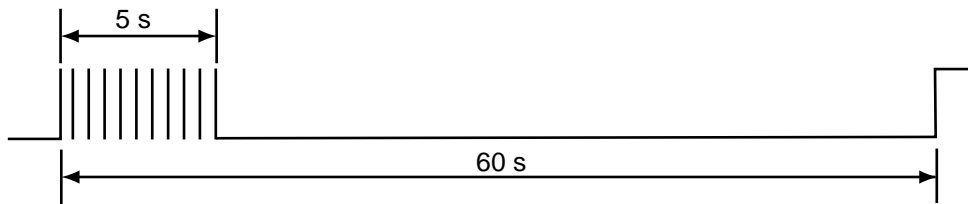

*Anchor signal*

AGND: Warning signal for vessels aground. Two bell tones of 0.5 seconds, a bell tone of 1 second followed by a rapidly ringing bell tone for a duration of 5 seconds, followed by a bell tone of 2 seconds and 0.5 seconds. Repeated once every 60 seconds.

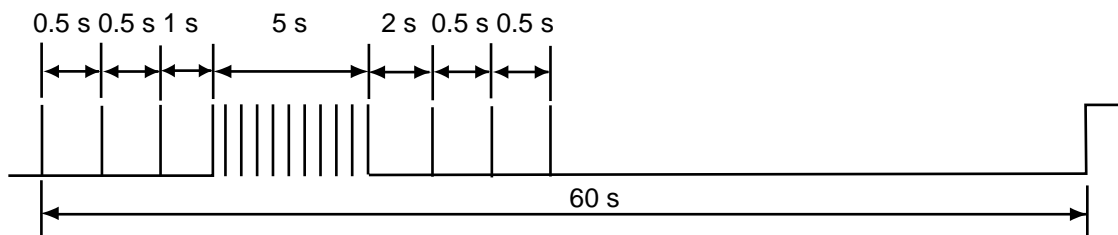

*Aground signal*

### Sounding a manual warning signal

1. Press the [Hail Select] key until the indicator lights for the desired horn speaker(s). If no selection is made, "BOTH" will be automatically selected when a warning signal is initiated.
2. Press the [Upper Signal Select] key to select YELP or press the [Lower Signal Select] key to select MAN. The indicator begins flashing for the desired signal.
3. Press the [FUNC] key to activate the warning signal. The indicator stops flashing and lights steadily.
4. Press the PTT switch on the microphone to sound the warning signal. Each time the PTT switch is pressed, the warning signal will sound until the PTT switch is released. When the PTT switch is released the equipment will return to the listen mode. Adjust the [LISTEN VOL] control if necessary.
5. To temporarily interrupt manual signals with voice transmissions do the following:
  - 1) Press the [Hail Select] key. The indicator for the chosen signal flashes to indicate the signal is still selected, but not active.
  - 2) Press the PTT switch on the microphone and speak into the microphone. Your voice will sound to all stations.
  - 3) Release the PTT switch again to return to manual warning signals.

## **Sounding an automatic warning signal**

1. Press the [Hail Select] key until the indicator lights for the desired horn speaker(s). If no selection is made, "BOTH" will be automatically selected when a warning signal is initiated.
2. Press the [Upper Signal Select key] to select UNWY, SAIL or TOW or press the [Lower Signal Select] key to select STOP, ANCH or AGND until the indicator flashes for the desired signal.
3. Press the [FUNC] key to activate the automatic warning signal. The indicator stops flashing and lights and then the signal is sounded from the selected horn speaker(s).
4. To temporarily interrupt automatic signals with voice transmissions, press the [FUNC] key. The indicator for the chosen signal flashes to indicate the signal is still selected, but not active.
5. Press the PTT switch on the microphone and speak into the microphone. Your voice sounds from the chosen horn speaker(s).
6. Release the PTT switch and press the [FUNC] key again to return to automatic warning signals.
7. To stop transmitting automatic warning signals, press the [FUNC] key followed by the [Hail Select] key to return to the standby mode.

## **Calling intercom stations while sounding warning signals**

### **Calling all intercom stations**

1. While pressing and holding down the [Hail Select] key, press the PTT switch. All intercom indicators flash.
2. Press the PTT switch on the microphone and speak into the microphone.
3. After speaking, release the PTT switch and then the [Hail Select] key to return to the chosen warning signal.

### **Calling a specific intercom station**

1. Press the [Intercom Select] key until the indicator lights on the desired intercom station. A short tone sounds from the selected intercom one second after choosing a station.
2. Press the PTT switch on the microphone and speak into the microphone.
3. Release the PTT switch to listen to the reply from the selected intercom station. If necessary, adjust the listening volume with the [LISTEN VOL] control.
4. After you have finished your conversation, press the [Hail Select] key to return to the standby mode. Signal activity on the selected horn speaker will be restored.

## **2.11 Transmitting the Auxiliary Signal**

### **Transmitting the auxiliary signal over all speakers**

An audio signal from an external audio source can be transmitted through the equipment via the AUX input connector on the rear panel.

1. In the standby mode, press the [AUX] key. The signal from the external AF source (radio, CD player, etc.) sounds from all intercom stations and any connected horn speakers. Adjust the output volume level directly from the external input source.
2. To turn off the external AF signal, press the [AUX] key to return to the standby mode.

### **Transmitting the auxiliary signal over all intercom stations**

1. Press and hold the [Intercom Select] key.
2. Press the [AUX] key.

### **Returning auxiliary transmission to standby mode**

Press the [AUX] key twice.

## 2.12 Alarm Mode

The LH-3000 can operate as a burglar alarm by connecting an external, normal-open switch to the ALRM terminals on the rear panel.

Both horn speakers are selected automatically when the alarm mode is enabled. If the alarm is triggered, the volume output is automatically set to maximum.

### Enabling the alarm mode

1. Press and hold down the [Upper Signal Select] key until the YELP indicator flashes. Note that you may light the MAN indicator (with the [Lower Signal Select] key) instead of the YELP indicator.
2. Press the [FUNC] key until the ALL, FWD, AFT and BOTH indicators light. The YELP indicator goes off.
3. After approximately five minutes, the ALL, FWD, AFT and BOTH indicators go off. Then the equipment goes into standby, lighting the BOTH indicator every four seconds to indicate standby mode.

See the next page for procedure flow.

### When an attempt is made to remove the Loud Hailer

When an attempt is made to remove the Loud Hailer, the alarm sound is released through both horn speakers at maximum volume. The alarm sounds for two minutes followed by a five-minute rest time. The BOTH indicator lights every four seconds during the sounding of the alarm or the five-minute rest period.

### Disabling the alarm mode

Press any key or switch other than the [AUX] or [DIM] key, or turn off the power.

2. OPERATION

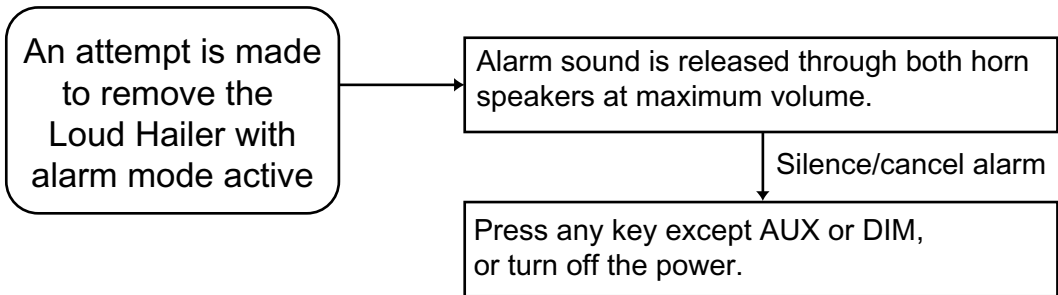
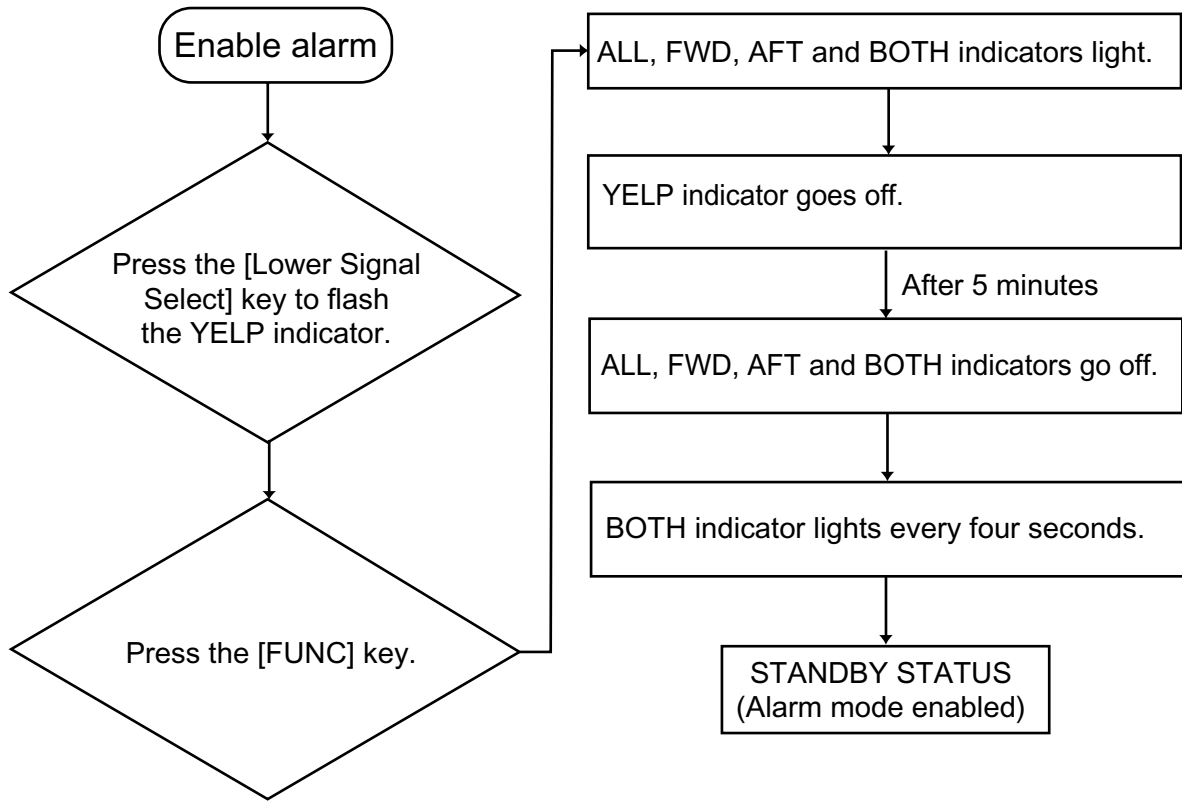

*Alarm setting/cancel flow*

# 3. MAINTENANCE, TROUBLESHOOTING

---

Periodic checks and maintenance are important for maintaining performance. This chapter contains maintenance and troubleshooting instructions to be followed to obtain optimum performance and the longest possible life of the equipment.



## **WARNING**

**Do not open the equipment.**

Only qualified personnel should work inside the equipment.

## 3.1 Preventive Maintenance

### General checks

Check the following monthly.

- Check all cabling. If damaged, replace.
- Check connections. Retighten if necessary.
- Measure the input voltage to be sure it is within the rated voltage (13.6 VDC  $\pm$ 20%).

### Cleaning

Dust or dirt should be removed from exterior surfaces with a soft, dry cloth. Do not use chemical-based cleaners to clean the Loud Hailer – they can remove paint and markings.

## 3.2 Replacing the Fuse

The 6A fuse inside the Loud Hailer protects it from reverse polarity and equipment fault. If the power cannot be turned on, the fuse may have blown. Have a qualified technician check the fuse.

 <b>WARNING</b>
<p><b>Use the proper fuse.</b></p> <p>Use of a wrong fuse can result in damage to the equipment or cause fire.</p>

## 3.3 Troubleshooting

Below are simple troubleshooting procedures which the user may follow to try to restore normal operation. If normal operation cannot be restored, do not attempt to check inside any unit. Any repair work is best left to a qualified technician.

*Troubleshooting table*

If...	Then...
power cannot be turned on	<ul style="list-style-type: none"> <li>• check that the power cable is tightly connected.</li> <li>• fuse may have blown. Have a qualified technician check the fuse.</li> </ul>
you cannot hear voice from an intercom station	<ul style="list-style-type: none"> <li>• adjust the [LISTEN VOL] control.</li> </ul>
output volume is too low	<ul style="list-style-type: none"> <li>• adjust the [HAIL VOL] control.</li> </ul>

**SPECIFICATIONS OF LOUD HAILER  
LH-3000****1 AUDIO OUTPUT**

- |     |                  |               |
|-----|------------------|---------------|
| 1.1 | Hail speaker     | 30 W, 8 ohms  |
| 1.2 | Intercom speaker | 4.5 W, 4 ohms |
| 1.3 | External speaker | 4.5 W, 4 ohms |
| 1.4 | Internal speaker | 2.5 W, 4 ohms |

**2 INPUT IMPEDANCE**

- |     |               |          |
|-----|---------------|----------|
| 2.1 | MIC impedance | 600 ohms |
| 2.2 | Aux impedance | 10K ohms |

**3 INPUT SENSITIVITY**

- |     |                 |                          |
|-----|-----------------|--------------------------|
| 3.1 | MIC sensitivity | -73 ±3 dB (0 dB=1V/μBar) |
| 3.2 | Aux sensitivity | 0 dBm ±3 dB (at 1 kHz)   |

**4 DISTORTION FACTOR**

- |     |               |                   |
|-----|---------------|-------------------|
| 4.1 | Hail mode     | 10% (1 kHz 30 W)  |
| 4.2 | Intercom mode | 10% (1 kHz 2.5 W) |

**5 SIGNAL-TO-NOISE**

- |     |               |               |
|-----|---------------|---------------|
| 5.1 | Hail mode     | 60 dB (1 kHz) |
| 5.2 | Intercom mode | 60 dB (1 kHz) |

**6 POWER SUPPLY & POWER CONSUMPTION**

12 VDC, less than 5A, less than 280 mA (standby)

**7 ENVIRONMENTAL CONDITIONS**

- |     |                     |                                  |
|-----|---------------------|----------------------------------|
| 7.1 | Ambient temperature | -15 to 55°C                      |
| 7.2 | Relative humidity   | 95% at 40°C                      |
| 7.3 | Waterproofing       | IPX5 (Front panel), IPX0 (Other) |

**8 COLOR**

N3.0

This page is intentionally left blank.

# PACKING LIST

LH-3000

05EB-X-9851 -0

1/1

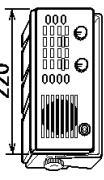

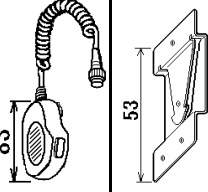
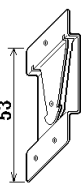
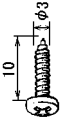
NAME	OUTLINE	DESCRIPTION/CODE	Q'TY
<b>ユニット UNIT</b>			
ラウド・ハイル- LOUD HAILER		LH-3000 000-040-004	1

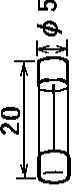
<b>マイクセット MICROPHONE SET</b>			
マイクホン MICROPHONE		DM-2003 999-999-022 ** FOR DM-2003	1
マイクホルダ MICROPHONE HANGER		999-999-023 ** 3X10	1
タップネジ +TAPPING SCREW		999-999-024 **	3

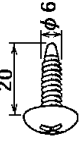
<b>予備品 SPARE PARTS</b>			
ヒューズ FUSE		FGMB 6A 125V 000-147-324	2

<b>工事材料 INSTALLATION MATERIALS</b>			
タップネジ +TAPPING SCREW		6X20 SUS304 171 000-802-084	4

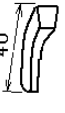
1.ユニット番号末尾の["\*\*"]は、タミコドに付き、注文できません。  
\*\* THIS CODE CANNOT BE ORDERED.

NAME	OUTLINE	DESCRIPTION/CODE	Q'TY
防振コシ RUBBER CUSHION		TZ7300030A 000-149-771	1
防振コシ RUBBER CUSHION		TZ7300031A 000-149-772	1

## 図書 DOCUMENT

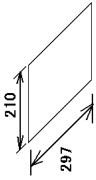
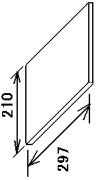
型紙 TEMPLATE		E52-00303-*	1
取扱説明書 OPERATOR'S MANUAL		000-149-157 OME-56460-*	1

(略図の寸法は、参考値です。 DIMENSIONS IN DRAWING FOR REFERENCE ONLY.)

05EB-X-9851

**FURUNO**

CODE NO.		05EB-X-9402 -0
TYPE		1/1

工事材料表 INSTALLATION MATERIALS					
番号 NO.	名称 NAME	略図 OUTLINE	型名 / 規格 DESCRIPTIONS	数量 Q'TY	用途 / 備考 REMARKS
1	2対ケーブル *20M* 2P TWISTED PAIR CABLE	 L=20M	CO-SPEVV-SB-C 0.2X2P	1	選択 TO BE SELECT
			CODE NO.		
2	2対ケーブル *15M* 2P TWISTED PAIR CABLE	 L=15M	CO-SPEVV-SB-C 0.2X2P	1	選択 TO BE SELECT
			CODE NO.		
3	2対ケーブル *10M* 2P TWISTED PAIR CABLE	 L=10M	CO-SPEVV-SB-C 0.2X2P	1	選択 TO BE SELECT
			CODE NO.		
4	2対ケーブル *5M* 2P TWISTED PAIR CABLE	 L=5M	CO-SPEVV-SB-C 0.2X2P	1	選択 TO BE SELECT
			CODE NO.		

05EB-X-9402

FURUNO ELECTRIC CO., LTD.  
 (略図の寸法は、参考値です。 DIMENSIONS IN DRAWING FOR REFERENCE ONLY.)

**FURUNO**

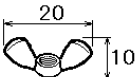
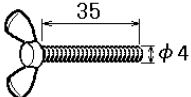
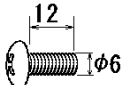
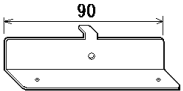
CODE NO.		000-149-112		05EB-X-9401 -0	
TYPE				1/1	
<b>フラッシュマウントキット</b> FLUSH MOUNT KIT.		LH-3020			
番号 NO.	名称 NAME	略図 OUTLINE	型名 / 規格 DESCRIPTIONS	数量 Q'TY	用途 / 備考 REMARKS
1	蝶ナット WING NUT		M4 SUS304 2ｼ1	4	(*)
			CODE NO. 999-999-028		
2	蝶ボルト WING SCREW		M4X35 SUS304 2ｼ1	4	(*)
			CODE NO. 999-999-027		
3	+トラスネジ SCREW		M6X12 SUS304	2	(*)
			CODE NO. 999-999-026		
4	フラッシュマウント金具 FLUSH MOUNTING PLATE		TZ7300012A	2	(*)
			CODE NO. 999-999-025		

注記：(\*)は、ダミーコードに付き、注文できません。

05EB-X-9401

\* THIS CODE CANNOT BE ORDERED.

FURUNO ELECTRIC CO., LTD.  
 (略図の寸法は、参考値です。 DIMENSIONS IN DRAWING FOR REFERENCE ONLY.)

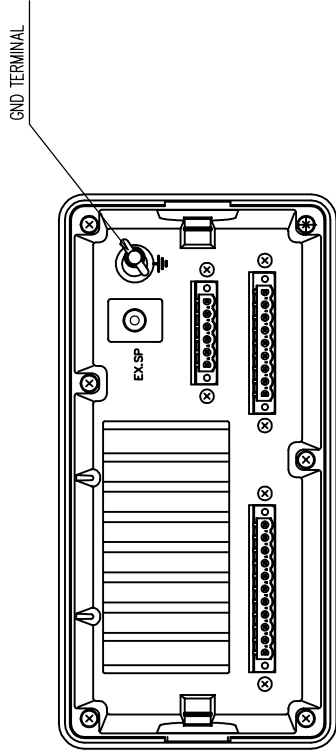
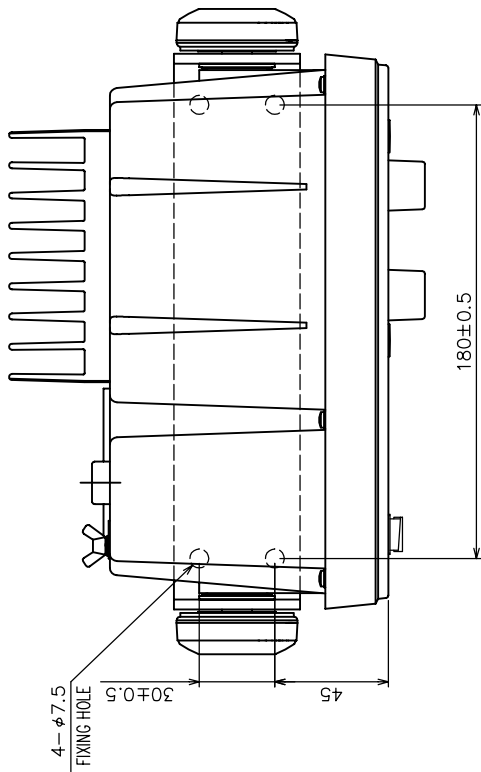

REAR VIEW

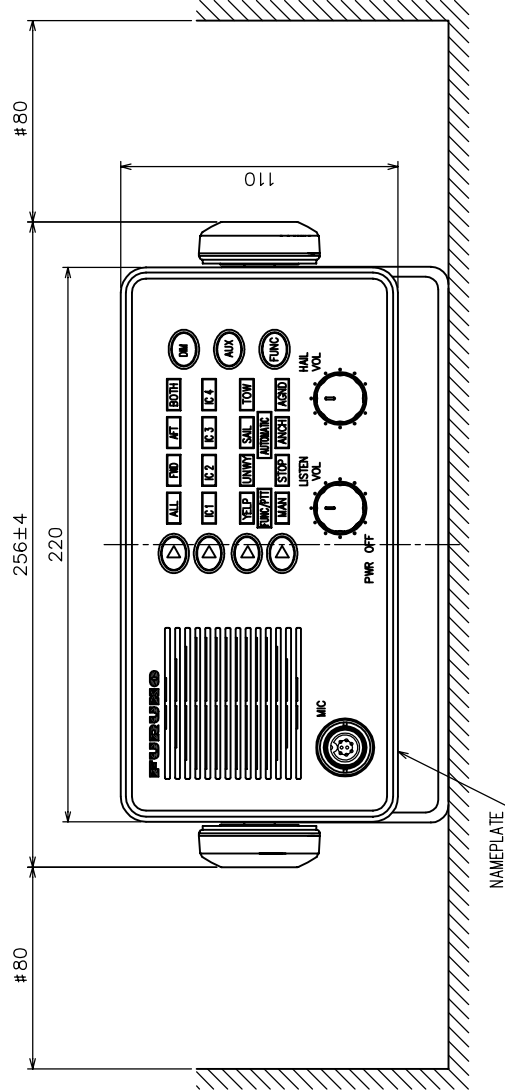

REAR VIEW

TABLE 1

DIMENSION (mm)	TOLERANCE (mm)
L ≤ 50	± 1.5
50 < L ≤ 100	± 2.5
100 < L ≤ 500	± 3

- NOTE 1. # MINIMUM SERVICE CLEARANCE.
- NOTE 2. TABLE 1 INDICATES TOLERANCE OF DIMENSIONS WHICH IS NOT SPECIFIED.
- NOTE 3. USE TAPPING SCREWS 6x20 FOR FIXING THE UNIT.

DATE	Jan. 21 '04	E. MIYOSHI	TITLE	LH-3000
CHECKED	T. akahashi T.		NAME	LOUD HAILER (DESKTOP MOUNT)
APPROVED	Y. Hatai		OUTLINE DRAWING	
SCALE	1/3	M/S	FIG. NO.	05-093-900G-2
DWG. No.	E5646-G01-A			

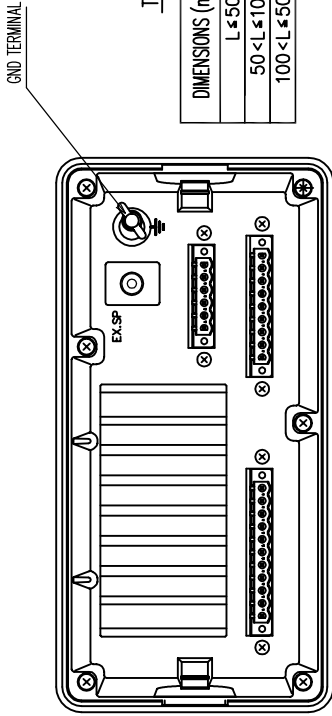
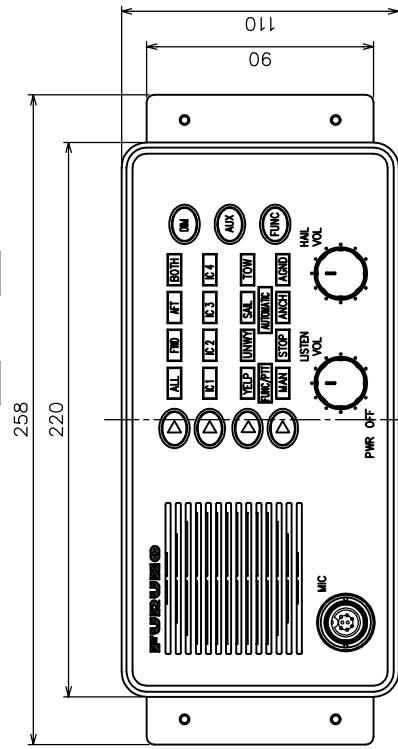
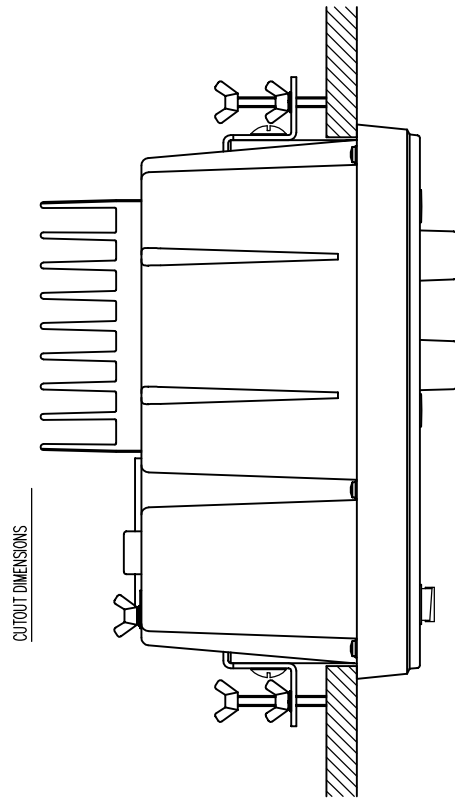
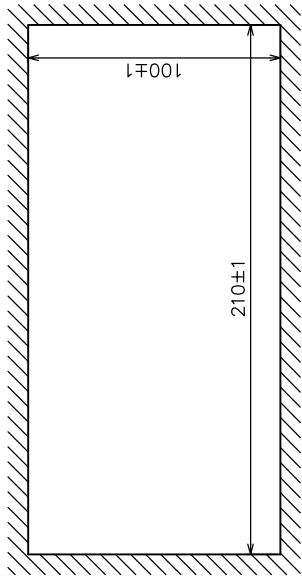
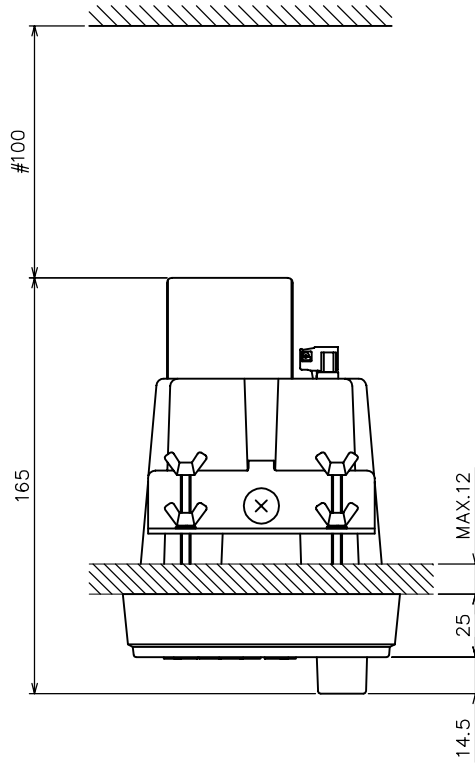

TABLE 1

DIMENSIONS (mm)	TOLERANCE (mm)
L±50	±1.5
50<L≤100	±2.5
100<L≤500	±3

REAR VIEW



NOTE 1. #: MINIMUM SERVICE CLEARANCE.

2. TABLE 1 INDICATES TOLERANCE OF DIMENSIONS WHICH IS NOT SPECIFIED.

DRAWN	Jan. 21/04	F. MIYOSHI	TITLE	LH-3000
CHECKED		Takahashi T.		各種
APPROVED		Y. Hatai		
SCALE	1/3	WAS 2.0	NAME	LOUD HAILER (FLUSH MOUNT)
DIR.No.	E5646-G02-A	05-093-910G-1		OUTLINE DRAWING





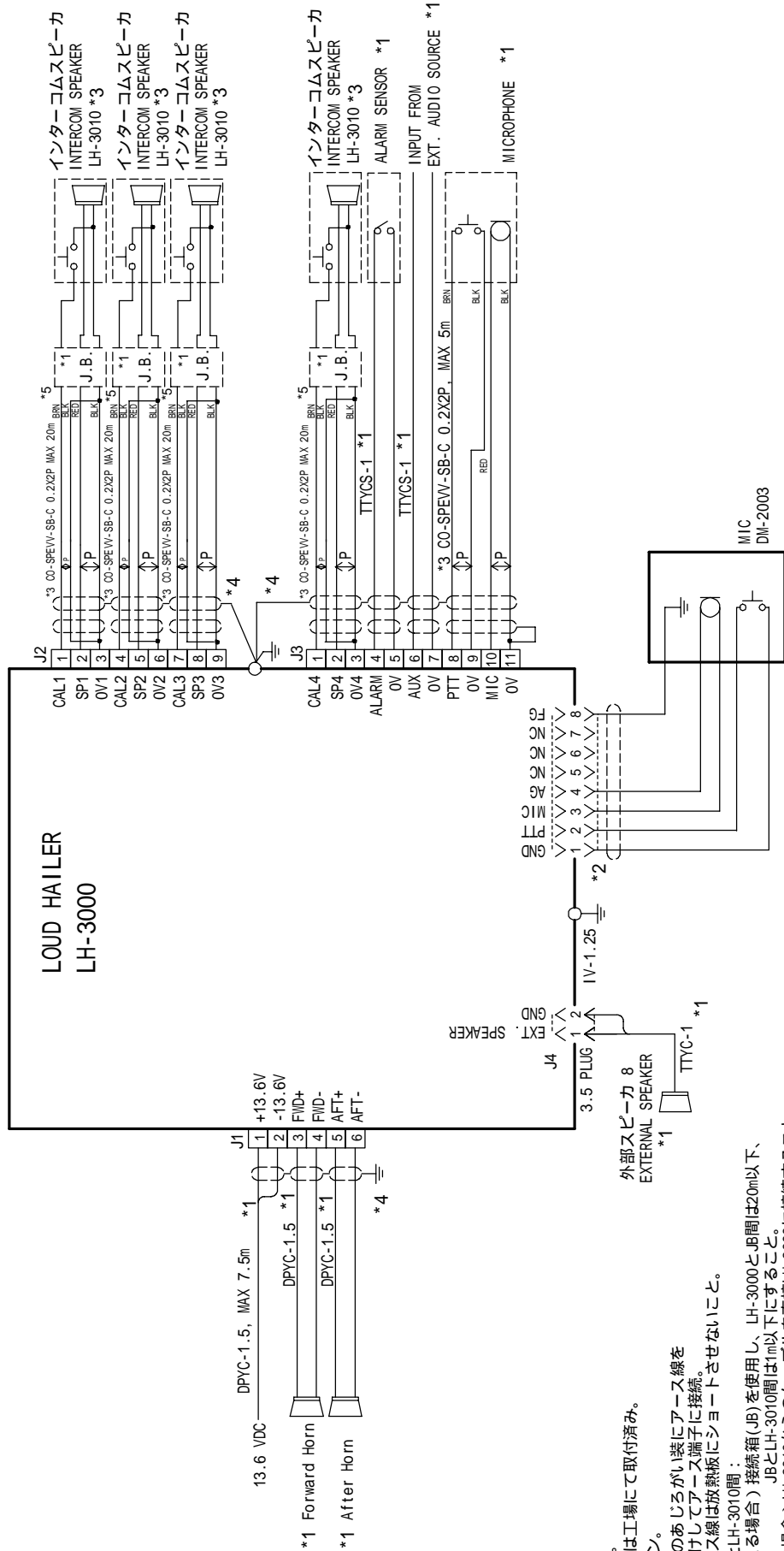

- 注記
- \*1) 現地手配。
  - \*2) コネクタは工場にて取付済み。
  - \*3) オプション。
  - \*4) ケーブルのあじろがい装にアース線をハンダ付けしてアース端子に接続。このアース線は放熱板にショートさせないこと。
  - \*5) LH-3000とLH-3010間：接続箱(JB)を使用し、LH-3000とJB間は20m以下、JBとLH-3010間は1m以下にすること。(2mを超える場合) LH-3010からのケーブルを直接LH-3000に接続すること。(2m以下の場合) LH-3010からのケーブルを直接LH-3000に接続すること。

NOTE

- \*1: LOCAL SUPPLY.
- \*2: CONNECTOR PLUGS FITTED AT FACTORY.
- \*3: OPTION.
- \*4: SOLDER DRAIN WIRE TO ARMOR OF CABLE AND CONNECT IT TO EARTH TERMINAL. DO NOT SHORT THE DRAIN WIRES ON THE HEAT SINK.
- \*5: CABLING BETWEEN LH-3000 AND LH-3010: USE JUNCTION BOX (JB) DISTANCE BETWEEN LH-3000 AND JB SHALL BE 20m OR LESS. DISTANCE BETWEEN JB AND LH-3010 SHALL BE 1m OR LESS. 2m OR LESS; CONNECT CABLE FROM LH-3010 DIRECTLY TO LH-3000.

DRAWN Aug. 5, '04 E. MIYOSHI	TITLE LH-3000
CHECKED TAKAHASHI, T	名称 ラウドヘイラー
APPROVED Y. Hatai	相互結線図 相対結線図
	NAME LOUD HAILER
	INTERCONNECTION DIAGRAM
DWG. No. CS646-C01-C	